

## -30V P-Channel Enhancement Mode MOSFET

### Description

The AP150P03P/T uses advanced trench technology to provide excellent  $R_{DS(ON)}$ , low gate charge and operation with gate voltages as low as 4.5V. This device is suitable for use as a Battery protection or in other Switching application.

### General Features

$V_{DS} = -30V$   $I_D = -150A$

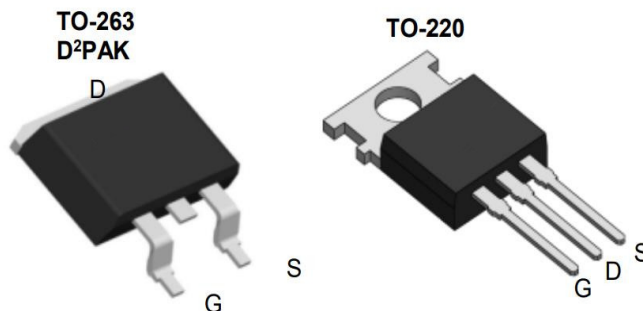
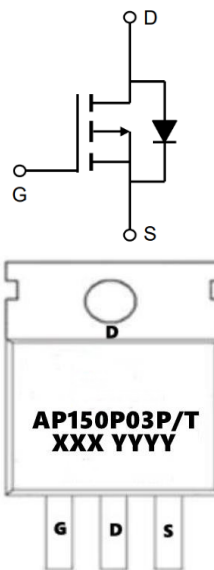
$R_{DS(ON)} < 5.5m\Omega$  @  $V_{GS} = -10V$  (Type: **3.8mΩ**)

### Application

Lithium battery protection

Wireless impact

Mobile phone fast charging



### Package Marking and Ordering Information

Product ID	Pack	Marking	Qty(PCS)
AP150P03P	TO-220-3L	AP150P03P XXX YYYY	1000
AP150P03T	TO-263-3L	AP150P03T XXX YYYY	800

### Absolute Maximum Ratings (TC=25°C unless otherwise noted)

Symbol	Parameter	Max.	Units
VDSS	Drain-Source Voltage	-30	V
VGSS	Gate-Source Voltage	±20	V
ID@TC=25°C	Continuous Drain Current TC = 25°C	-150	A
ID@TC=100°C	Continuous Drain Current TC = 100°C	-85	A
IDM	Pulsed Drain Current note1	-460	A
EAS	Single Pulsed Avalanche Energy note2	225	mJ
PD	Power Dissipation TC = 25°C	62.5	W
RθJC	Thermal Resistance, Junction to Case	1.46	°C/W
TJ, TSTG	Operating and Storage Temperature Range	-55 to +175	°C



## -30V P-Channel Enhancement Mode MOSFET

### Electrical Characteristics (T<sub>J</sub>=25°C, unless otherwise noted)

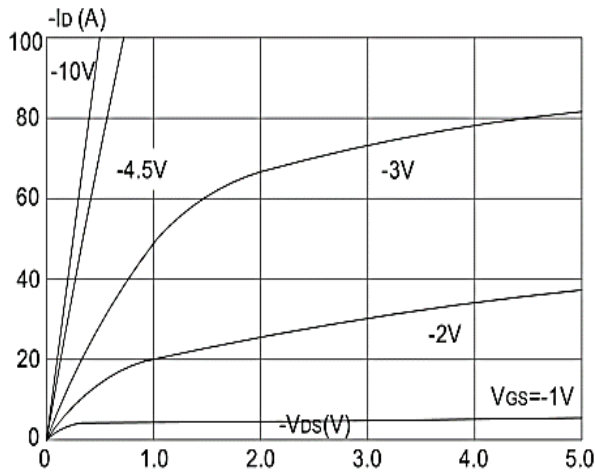
Symbol	Parameter	Test Condition	Min.	Typ.	Max.	Units
V(BR)DSS	Drain-Source Breakdown Voltage	VGS=0V, ID= -250μA	-30	-33	-	V
IDSS	Zero Gate Voltage Drain Current	VDS= -30V, VGS=0V,	-	-	-1	μA
IGSS	Gate to Body Leakage Current	VDS=0V, VGS= ±20V	-	-	±100	nA
VGS(th)	Gate Threshold Voltage	VDS=VGS, ID= -250μA	-1.0	-1.6	-2.5	V
RDS(on)	Static Drain-Source on-Resistance	VGS= -10V, ID= -30A	-	3.8	5.5	mΩ
		VGS= -4.5V, ID= -20A	-	5.8	8.2	
Ciss	Input Capacitance	VDS= -15V, VGS=0V, f=1.0MHz	-	9400	-	pF
Coss	Output Capacitance		-	1000	-	pF
Crss	Reverse Transfer Capacitance		-	767	-	pF
Qg	Total Gate Charge	VDS= -15V, ID= -30A, VGS= -10V	-	42	-	nC
Qgs	Gate-Source Charge		-	8.4	-	nC
Qgd	Gate-Drain("Miller") Charge		-	11.2	-	nC
td(on)	Turn-on Delay Time	VDD= -15V, ID= -30A, VGS= -10V, RGEN=2.5Ω	-	15	-	ns
tr	Turn-on Rise Time		-	16	-	ns
td(off)	Turn-off Delay Time		-	69	-	ns
tf	Turn-off Fall Time		-	27	-	ns
IS	Maximum Continuous Drain to Source Diode Forward Current		-	-	-90	A
ISM	Maximum Pulsed Drain to Source Diode Forward Current		-	-	-360	A
VSD	Drain to Source Diode Forward Voltage	VGS=0V, IS= -30 A		-0.8	-1.2	V

#### Notes:

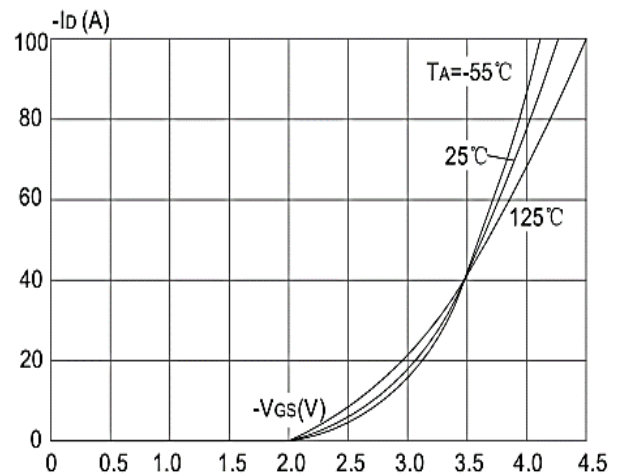
- 1、 The data tested by surface mounted on a 1 inch<sup>2</sup> FR-4 board with 2OZ copper.
- 2、 The data tested by pulsed , pulse width ≅ 300us , duty cycle ≅ 2%
- 3、 The EAS data shows Max. rating . The test condition is T<sub>J</sub> =25°C , V<sub>DD</sub> = -15V, V<sub>G</sub> = -10V, R<sub>G</sub> =25Ω, L=0.5mH, I<sub>AS</sub>=-30A
- 4、 The power dissipation is limited by 150°C junction temperature
- 5、 The data is theoretically the same as I<sub>D</sub> and I<sub>DM</sub> , in real applications , should be limited by total power dissipation.

**-30V P-Channel Enhancement Mode MOSFET**

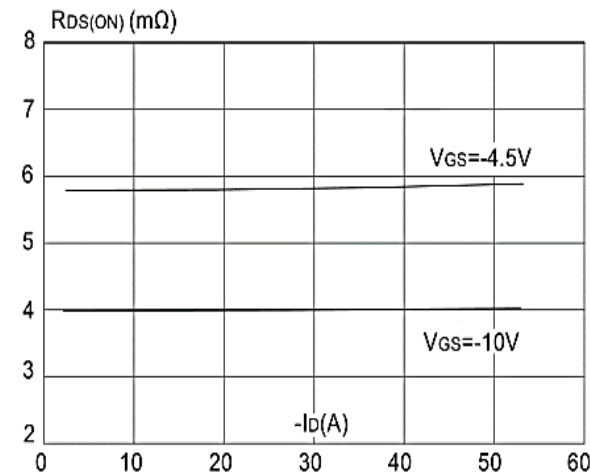
**Typical Characteristics**



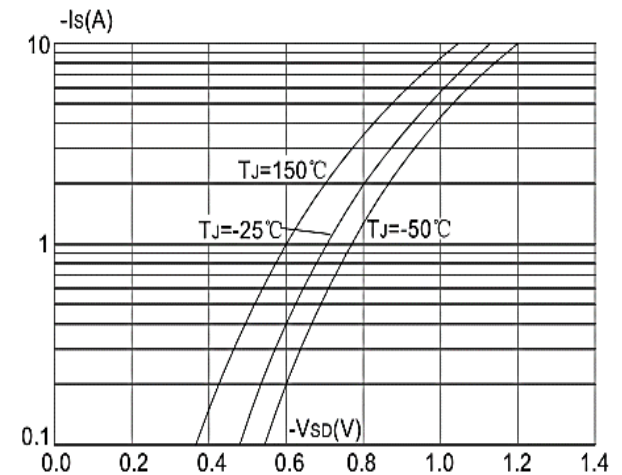
**Figure 1: Output Characteristics**



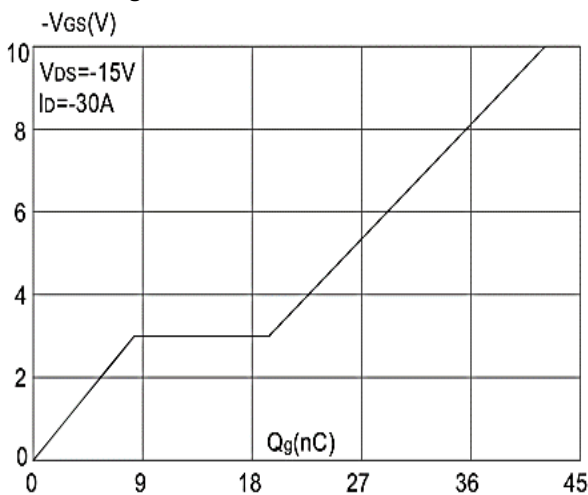
**Figure 2: Typical Transfer Characteristics**



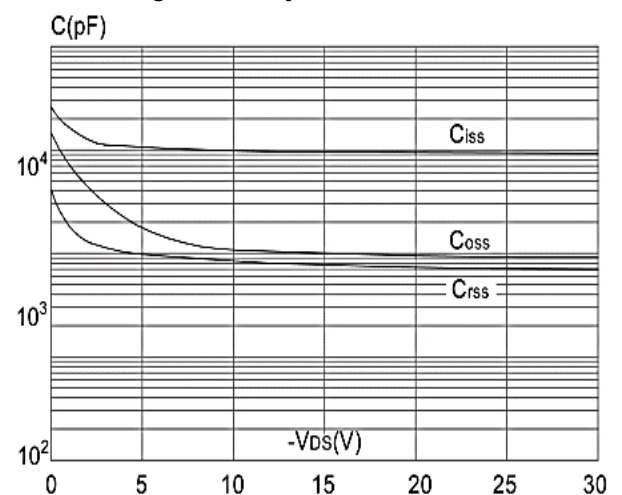
**Figure 3: On-resistance vs. Drain Current**



**Figure 4: Body Diode Characteristics**

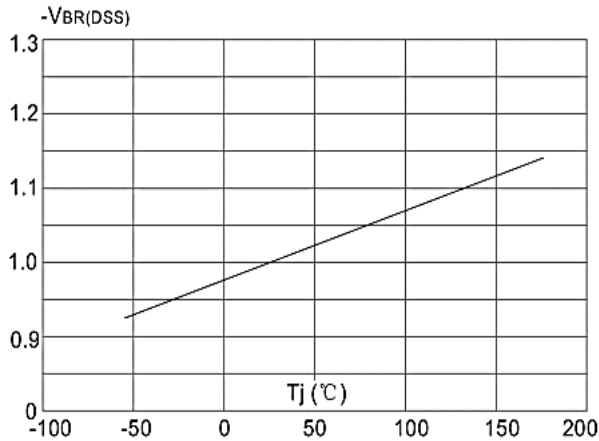


**Figure 5: Gate Charge Characteristics**

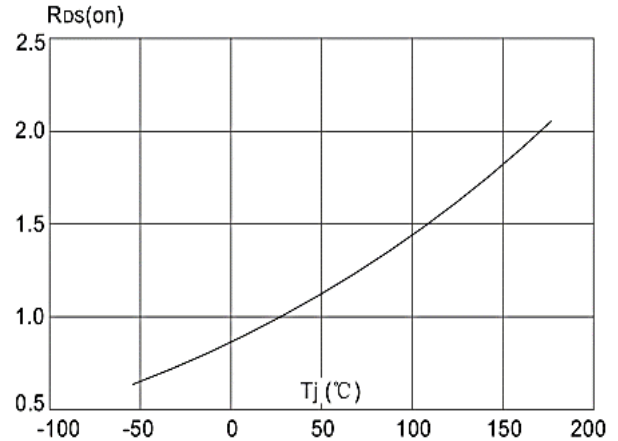


**Figure 6: Capacitance Characteristics**

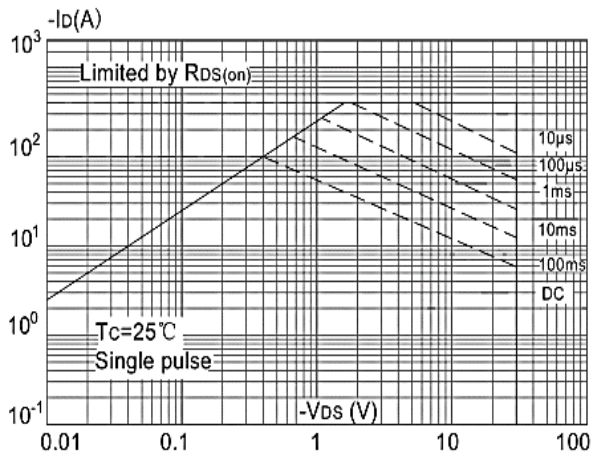
**-30V P-Channel Enhancement Mode MOSFET**



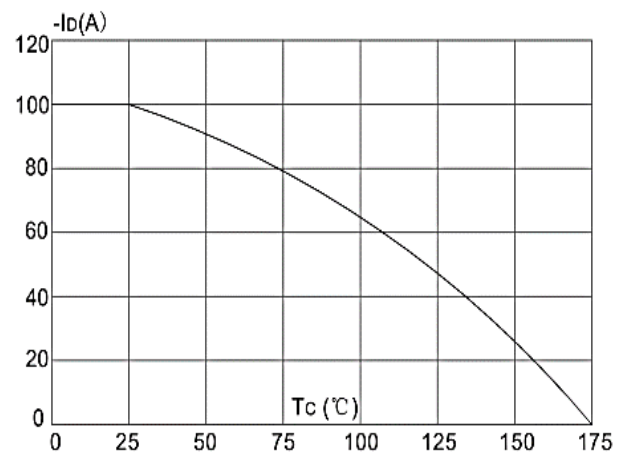
**Figure 7: Normalized Breakdown Voltage vs. Junction Temperature**



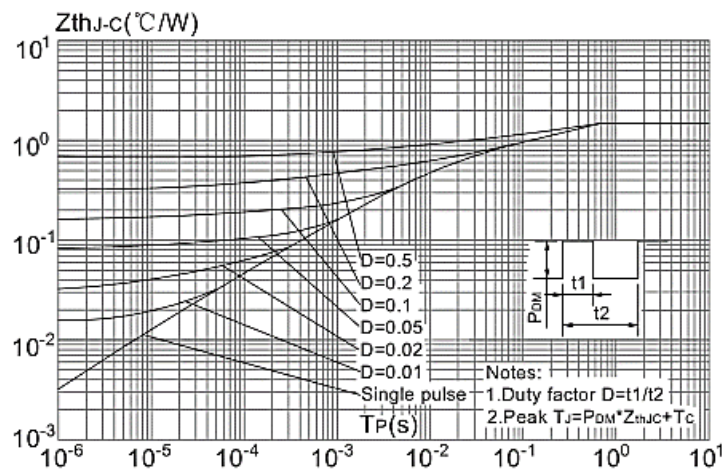
**Figure 8: Normalized on Resistance vs. Junction Temperature**



**Figure 9: Maximum Safe Operating Area**



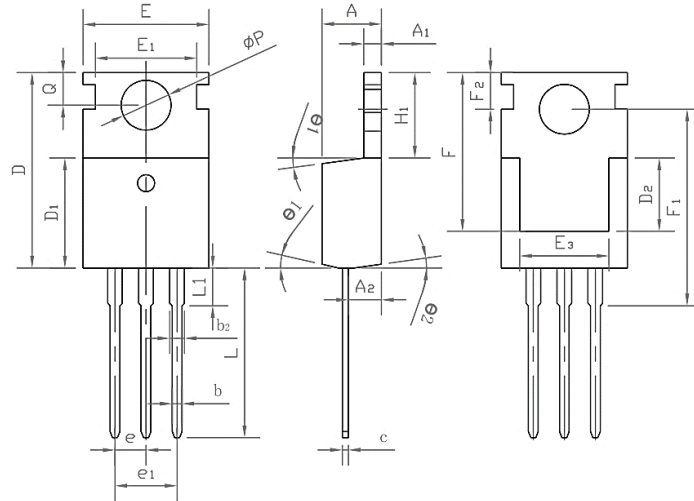
**Figure 10: Maximum Continuous Drain Current vs. Case Temperature**



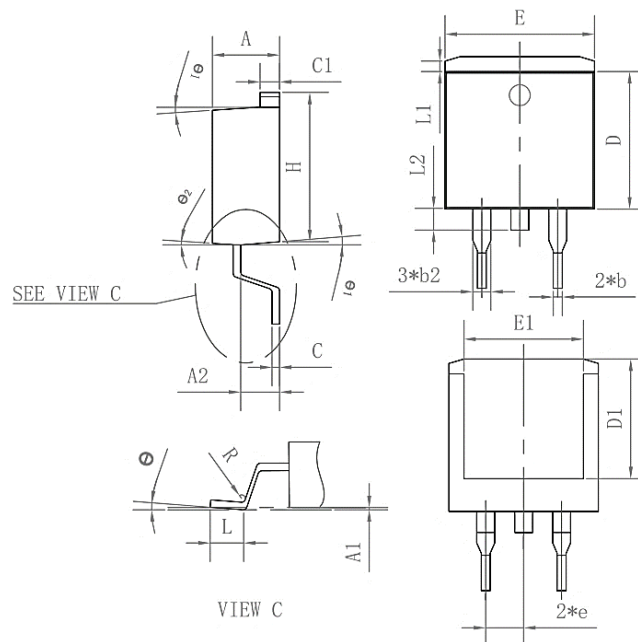
**Figure.11: Maximum Effective Transient Thermal Impedance, Junction-to-Case**

## -30V P-Channel Enhancement Mode MOSFET

### Package Mechanical Data-TO-220-3L-SLK



Symbol	Common		
	mm		
	Mim	Nom	Max
A	4.27	4.57	4.87
A1	1.15	1.30	1.45
A2	2.10	2.40	2.70
b	0.70	0.80	1.00
b2	1.17	1.27	1.50
D	0.40	0.50	0.65
D1	8.80	9.10	9.40
D2	5.70	6.70	7.00
E	9.70	10.00	10.30
E1	-	8.70	-
E2	9.63	10.00	10.35
E3	7.00	8.00	8.40
e	0.37		
e1	0.10		
H1	6.00	6.50	6.85
L	12.75	13.50	13.90
L1	-	3.10	3.40
Φp	3.45	3.60	3.75
Q	2.60	2.80	3.00
θ1	4°	7°	10°
θ2	0°	3°	6°
F	13.30	13.50	13.70
F1	15.50	15.90	16.30
F2	2.80	3.00	3.20

**-30V P-Channel Enhancement Mode MOSFET**
**Package Mechanical Data-TO-263-3L-SLK**


Symbol	Common		
	mm		
	Mim	Nom	Max
A	4.35	4.47	4.60
A1	0.09	0.10	0.11
A2	2.30	2.40	2.70
b	0.70	0.80	1.00
b2	1.25	1.36	1.50
C	0.45	0.50	0.65
C1	1.29	1.30	9.40
D	9.10	9.20	9.30
D1	7.90	8.00	8.10
E	9.85	10.00	10.20
E1	7.90	8.00	8.10
H	15.30	15.50	15.70
e	-	2.54	-
L	2.34	2.54	2.74
L1	1.00	1.10	1.20
L2	1.30	1.40	1.50
R	0.24	0.25	0.26
θ	0°	4°	8°
θ1	4°	7°	10°
θ2	0°	3°	6°